

PRODUCT INFO

DOWNTOWN TWO QL3.1

Bike briefcase with QL3.1 system and flap closure

QL3.1 system

IP 53

PS36C

PVC free



Laptop compartment included



- ← Fixing for shoulder strap
- ← Flap with adjustable hook closure
- ← Robust metal hooks
- ← Reflective logo
- ← Adjustable, removable shoulder strap
- ← Anti-slip shoulder pad



Notebook sleeve for laptops
(dimensions 27cm x 40cm x 3cm /
10.6in. x 15.7 in. x 1.2 in)



- ← Carrying handle
- ← QL3.1 handle for releasing the mounting
- ← Top QL3.1 mounting
- ← Clean reverse side of bag without hooks protruding
- ← Lower QL3.1 mounting
- ← Abrasion protection on rear left and right corners
- ← Buttons to save the bag when putting it down

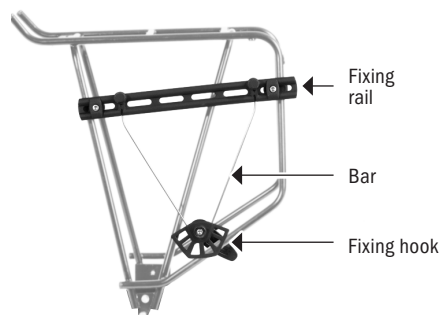

QL3/QL3.1 mounting set (included)

Material	height cm/in.	width cm/in.	depth cm/in.	vol L/cu.in.	weight g/oz.	max. capacity kg/lbs
PS36C	31/12.2	40/15.7	14/5.5	20/1220	1290/45	9/20

SPECIFICATIONS:

- + Waterproof briefcase (single bag) with flap closure adjustable in height
- + PU-laminated Cordura
- + Quick access flap closure with one metal hook
- + QL3.1 mounting system
- + Mounting of fixing components on rack
- + Single-handed mounting and removal of the bag
- + Flat fixing elements ensure plane reverse side of bag
- + Height and angle of bag individually adjustable
- + Lower mounting hook rotatable
- + Padded sleeve for laptop or mobile end devices (10.6 in. x 15.7 in. x 1.2 in.)
- + Organizer with 2 zippered pockets and sleeves, pen holder, snaphook for keys
- + Carrying handle and wide, padded and adjustable shoulder strap
- + Reflective Ortlieb logo
- + Two highly luminous 3M Scotchlite reflectors

Contents: Bag comes with padded shoulder strap, QL3.1 mounting components

Attention: Remove the shoulder strap or put it inside the bag before cycling

Optional accessories: QL3/QL3.1 mounting clamps for rack with 11 to 14 mm tubes, QL3.1 mounting set for second bike

Attention: Maximum load per pannier is 9kg / 20 lbs. We recommend weighing each loaded pannier to confirm that the maximum allowance of the pannier fixation is not exceeded. This practice is advised for both rear and front panniers. CAUTION: The maximum weight capacity of every carrier model is different. Please observe the maximum weight allowance of the carrier fitted to your bicycle. Note: Sometimes the maximum capacity of the panniers fixing system can exceed the maximum capacity of the carrier. DO NOT exceed the maximum capacity of the carrier! Note, that the use of panniers will significantly influence the handling properties of your bicycle.

Attention: As abrasion cannot be ruled out, we recommend that all points where the mounting system contacts the bicycle rack or frame be protected by scratch protection film.

Note: In order to meet standard IP53 (5=protected against dust, 3=protected against spray watermax. 60° to the vertical) the closure must be completely closed.